



PROJECT		REF		REV	ITEM CODE	
LOCATION		DATE			PAGE	

SANITARY WARE SPECIFICATION SHEET

Item Descriptions	Stern (Israel) "Tubular SD" Chrome plated wall mounted liquid soap dispenser in AC Supply with 5m wire AC 110-240 Vac 50/60Hz to 12V 2.5A IP68 waterproof switching transformer
Dimensions	L150 x W28 x H28 mm
Model	Tubular Soap Dispenser E
Code Number	350925
Finish	Chrome Plated
Supplier	Acme Sanitary Ware Co. Ltd Mr. Eric Wong/ Mr. Don Yuen
Contact Tel/Fax	(852) 2388-7171 / (852) 2710-8012
E-mail	acme@acmesanitary.com.hk
Website	www.acmesanitary.com.hk

Illustration/ Drawing

(UK plug or wire fuse)

Installation:
Wall mounted concealed

Power source:
12 V transformer

Stern Soap & Water:
Tubular matching faucet

Default soap dosage:
1.4 cc

Soap viscosity:
100-3800 cPs

TUBULAR SOAP DISPENSER E

Ref # 350925

Touch free electronic soap dispenser for wall mounted installations. Activated by infrared Sensor. Chrome plated body, other finishes available. Includes a 1 liter soap bottle and bottle support. Optional for remote installation: extension cable and longer piping. The following functions can be performed by using Stern remote control: Soap quantity selection, Refill the soap tank, temporary off, coming back to factory settings.

*Versions for multifeed installation available.

Application:
Closing automatically without dripping, Stern's touch free soap dispenser helps to ensure that the bathroom will stay organized and neat. Combined with Tubular touch free electronic faucet, it creates a germ-free and automated environment.

Use:
Touch free electronic soap dispenser. The soap dispenser is activated automatically when the users bring their hands within the sensor range and stops when the users remove their hands.

PRODUCT AT A GLANCE	
Installation	Wall mounted
Power Supply	<ul style="list-style-type: none"> Battery Box for 6D batteries. 12V Transformer
Soap	1 Liter soap bottle. This soap dispenser includes a peristaltic pump that allows the use of any kind of liquid soap, detergent or antibacterial gel.
Soap dosage	Factory setting of 1.2 to 1.6 cc depending on the selected soap. The soap quantity can be changed using the soap dispenser remote control.
Refill	Easy to use manual refill button used for soap priming. This function can also be performed with the remote control.

ORDERING INFORMATION	
PRODUCT NAME	PART NUMBER
Tubular soap dispenser B	350920
Tubular soap dispenser E	350925
Tubular SD B 6-pack	350921
Tubular SD E 6-pack	350926

OPTIONAL ACCESSORIES	
PRODUCT NAME	PART NUMBER
Remote Control for liquid soap dispensers	07100008

* All information of the above is for the reference only. No prior notice is made if any changes.



PROJECT		REF		REV	ITEM CODE	
LOCATION		DATE			PAGE	

SPARE PARTS LIST

**Tubular Soap Dispenser E
(350925)**

Quantity	Part Number	Description	Cat. No.
	-	Seals and Screws Kit	07210098
1	1	O-ring	
1	2	O-ring	
2	3	Screw	
2	8	Screw	
2	9	Anchor	
2	10	Screw	
	4	Electronic Unit	08002195
	5	Pump Soap Dispenser	07222001
	6	Bottle 1L support	07120175
	7	Soap Tank 1L	07100020
	11	Transformer	TBC

Note: In order to locate the relevant spare part, please check the corresponding parts and part number in the drawing. Minimum order quantity will be required.

** All information of the above is for the reference only. No prior notice is made if any changes.*



INSTALLATION

Tubular Soap Dispenser E

Step 1 – Preparing for installation

1. Drill a hole (23 to 24 mm) at the desired location for the soap dispenser spout installation.

Drill a small hole (3.2 mm) just above the previous one for the anti-rotation pin, according to the diagram.

3. Remove the hexagonal nut and the disk from the base of the soap dispenser spout.

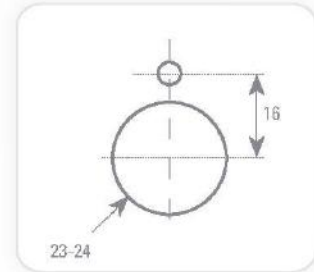

Step 2 – Installing the soap dispenser

1. Insert the Soap dispenser base.
2. Insert the anti-rotation pin into the small hole.
3. Fix the base behind the wall with the hexagonal nut and the disk.

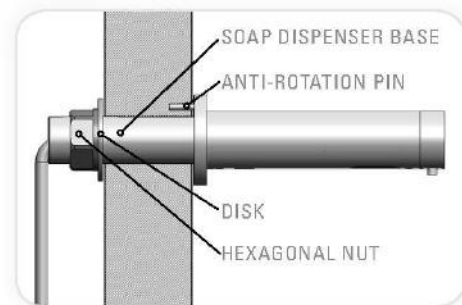

4. Fix the bottle support to the desired location.

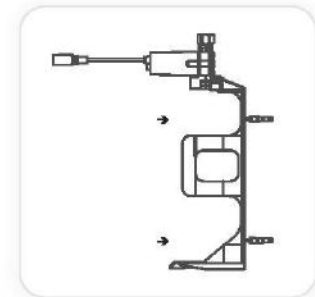

5. Assemble the tube from the pump to the soap dispenser.

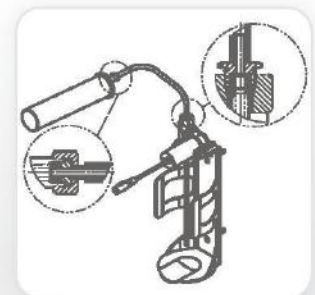



INSTALLATION

Tubular Soap Dispenser E

Step 3 - Connecting the power source

1. Remove the protective sticker covering the sensor. Keep away from the sensor range and check that no objects are in front of the sensor.



2. a. Connect the motor connector to the power source connector. Please note that since the connector is water proof, some friction might apply.

Important: the 4 contacts connector should be connected properly so that the white o-ring is not visible and a clicking sound is heard.
Pay attention: If the 4 contacts connectors will not be connected properly, the motor will work continuously.



O-ring visible – not connected properly



Connected properly so that only the grooves are visible

b. For battery versions: install the battery box at the wall underneath the sink and connect the battery connector

c. For transformer versions: plug the transformer into the electricity socket and connect the transformer connector

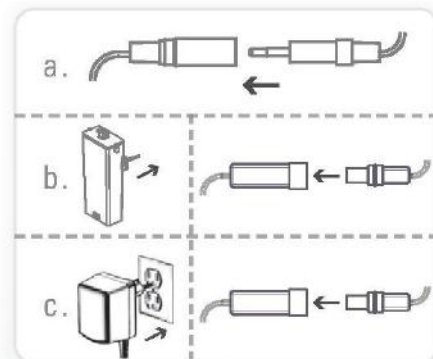

3. Wait about 10 seconds before you put your hands within the sensor range.

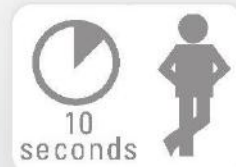



TROUBLE SHOOTING

PROBLEM	INDICATOR	CAUSE	SOLUTION
No soap coming out of the spout	Red light in the sensor flashes continuously when the user's hands are within the sensor's range.	Low battery.	Replace battery.
		Soap has run low or completely out.	Refer to page 4 and refill the soap tank.
	Red light in the sensor flashes (once) and the motor is operating.	The soap tank has been filled but soap has not reached the spout.	Press the refill button located at the bottom of the pump until soap starts to come out of the spout again.
		The connectors between the motor and the power source are not connected properly.	Connect the connectors all the way through. Refer to page 7 to see how.
		Sensor is picking up reflections from the washbasin or another object.	Eliminate cause of reflection.
	Red light in the sensor does not flash (once) when user's hands are within the sensor's range.	Connectors between the electronic unit and the pump assembly \ transformer are disconnected or not properly connected.	Connect the electronic unit connectors to the pump assembly and transformer.
		Battery is completely used up.	The battery must be replaced.
Red light flashes (once) and the motor operates.	Soap solidification at the pipe.	Fill the bottle with hot water at 50/60C and run the pump constantly.	
		Soap coming out from the spout does not stop	The black connector between the pump assembly and soap dispenser are not connected all the way through.